



2342 SHELTER SYSTEM

Features and Benefits

- Rapid deployment without aid of ancillary equipment, no tools necessary
- Vertical walls to maximize usable square footage of over 840 sq. ft
- Sealable vinyl floor maintains environmentally secure shelter
- Can be configured with roof or walls only for maximum flexibility in deployment
- Interior frame allows access to horizontal support bars capable of hanging supplies up to 50 lbs
- Rigid double doors provide a large entryway with ramp, to allow use of wheel chairs, gurneys and movement of large equipment in and out of shelter
- Roof vent caps significantly reduce condensation
- Assemble and disassemble in 30 to 50 minutes with a 6 to 8 person crew
- Framework design allows individual replacement of parts
- Flame retardant vinyl allows for safe occupation of shelter
- UV resistant, resists mildew and abrasion for longer life

Components

- Aircraft grade aluminum mainframe assembly
- Wiring harness with 16 outlets
- 14 oz. vinyl wall panels (8)
- 14 oz. vinyl roof panel
- 18 oz. sealable vinyl floor
- Double door with door ramp (2)
- Roof vent cap (2)
- High-wind tie down kit
- Expansion wall strips
- Vinyl repair kit
- Vinyl storage/transport bags

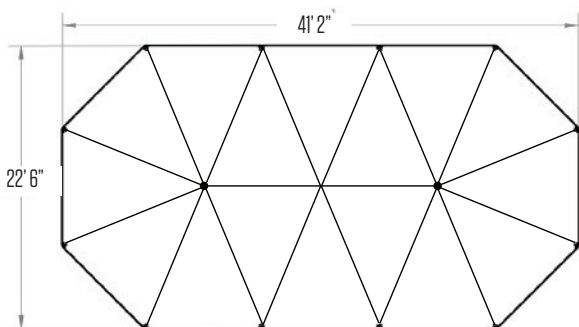

Specifications

Usable Area	22' 6" x 41' 2"	(6.85 x 12.5 m)
Total Weight	769 lbs	(348.8 kg)
Environment	-20°F to 140°F	(-40°C to 60°C)
Snow Load	10 lbs / ft ² for 12 hrs	(50 kg / m ² for 12 hrs)
Wind Load	55 mph w/gusts to 65 mph	(89 km/h w/gusts to 105 km / h)
Time Under Canopy	30 min / 4 personnel	
Total Set-Up Time	50 min / 6 personnel	
Square Footage	840 ft ²	(78 m ²)
Cube	7,071 ft ³	200.2 m ³

Dimensions

Footprint	22' x 6" x 41' 2"	(6.85 x 12.5 m)
Sidewall	6'	(1.8m)
Peak	12'	(3.6m)

Packaged Dimensions

			Weights	
Roof	21 x 23 x 14"	(53 x 58.5 x 35.5 cm)	108 lbs	(48.9 kg)
Door (4)	26 x 3.5 x 72"	(66 x 9 x 183 cm)	90 lbs	(40.8 kg)
Walls	28 x 28 x 14"	(71 x 71 x 35.5 cm)	121 lbs	(54.8 kg)
Vinyl Floor	23 x 20 x 14"	(58.5 x 51 x 35.5 cm)	130 lbs	(58.9 lbs)
Frame (2)	91 x 16 x 16"	(231 x 40.5 x 40.5 cm)	532 lbs	(241.3 lbs)

Berry Compliant ✓